

Spare Parts List

2 Posts Lift

Model NSP3500N

(Wide Model with Symmetric Arms)

Production Year - April 2016~

(Without Pricing)

Contents

	(Page)
Contents	1)
1 Overall View	2) ~ 3)
2 Post & Base	4) ~ 5)
3 Cylinder	6) ~ 7)
4 Main Carriage Assy	8) ~ 9)
5 Sub Carriage Assy	10) ~ 11)
6 Hyd. Unit and Control etc.	12) ~ 15)
7 Synchronizing Chain and Piping	16) ~ 17)
8 Lift Arm R·L and Parts	18) ~ 19)
9 History and Applicable Adjustable Supporter Assy (Information for Reference Only)	20) ~ 21)
10 Optional Frame Attachment (Truck Adaptor)	22) ~ 23)
11 Caution Labels	24)

Overall View

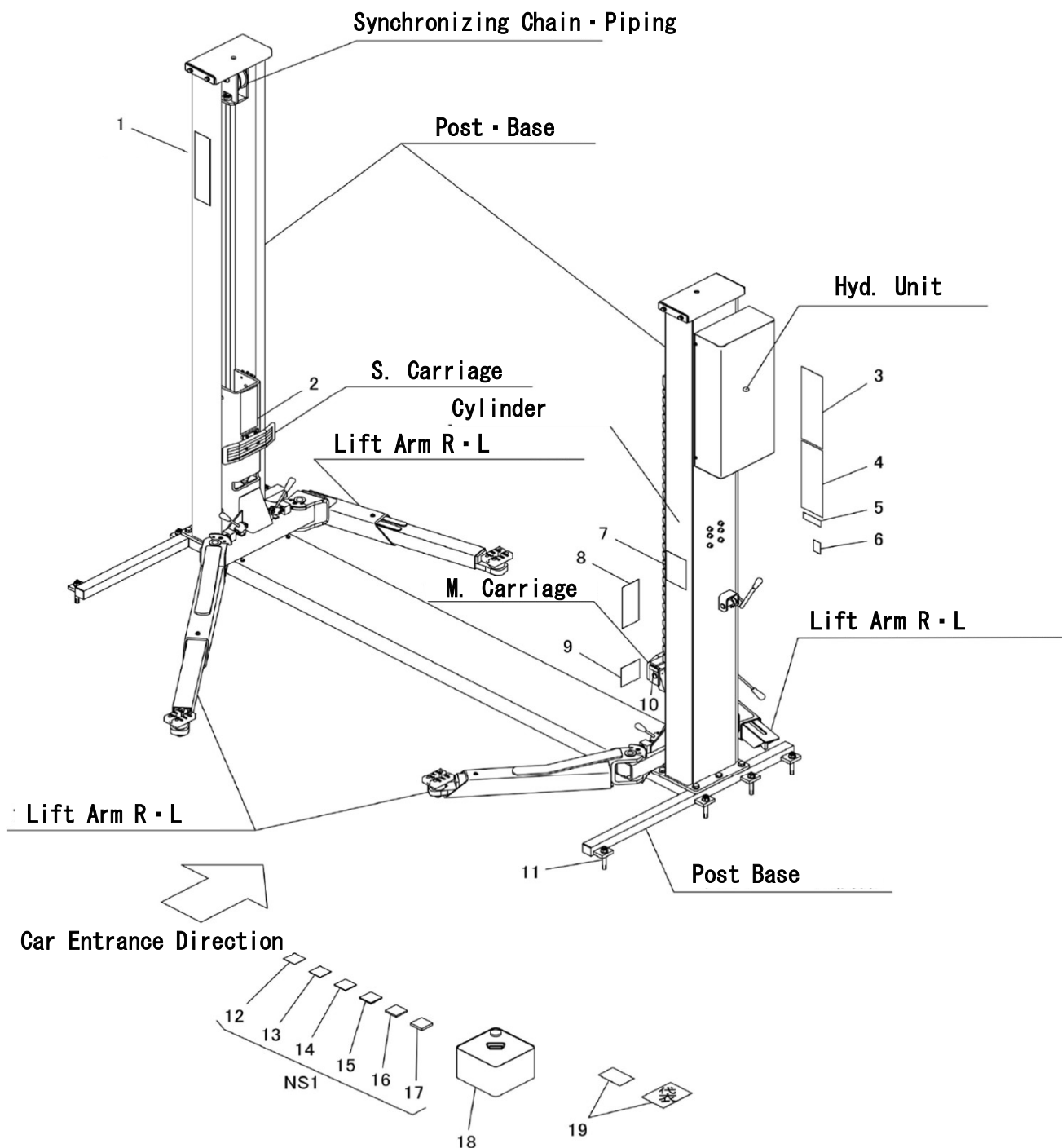

Overall View

NSP3500N

Ill. No.	Parts No.	Parts Name	Standard	Change Date & Note	Qty /Unit	Price/ea.
NS1	10163782	Shim Set	(12~17)		1 set	
1	51311024	Bishamon Label	Refer to Page 26		1	
2	11261840	Caution Label G	Refer to Page 26		1	
3	51311740	Caution Label M	Refer to Page 26		1	
4	51311381	Caution Label I	Refer to Page 26		1	
5	Ask	Serial Plate	Ask Bishamon		1	Ask
6	51311420	Function Sticker D	Refer to Page 26		1	
7	11261860	Caution Label H	Refer to Page 26		1	
8	11261820	Caution Label F	Refer to Page 26		1	
9	11261920	Caution Label	Refer to Page 26		1	
10	51311400	Function Sticker C	Refer to Page 26		1	
11	91011612	Anchor Bolt	AAC-1612		12	
12	10163711	Shim (0.8mm)	0.8 X 50 X 50		10	
13	10163721	Shim (1.6mm)	1.6 X 50 X 50		10	
14	10163731	Shim (3.0mm)	3.0 X 50 X 50		10	
15	10163741	Shim (4.5mm)	4.5 X 50 X 50		10	
16	10163751	Shim (6.0mm)	6.0 X 50 X 50		2	
17	10163761	Shim (9.0mm)	9.0 X 50 X 50		2	
18	50564841	Bishamon Oil (8L)	Option		1	
19	38000656	Chain & Cable Replacing Schedule Label			1	

Post & Base

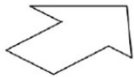
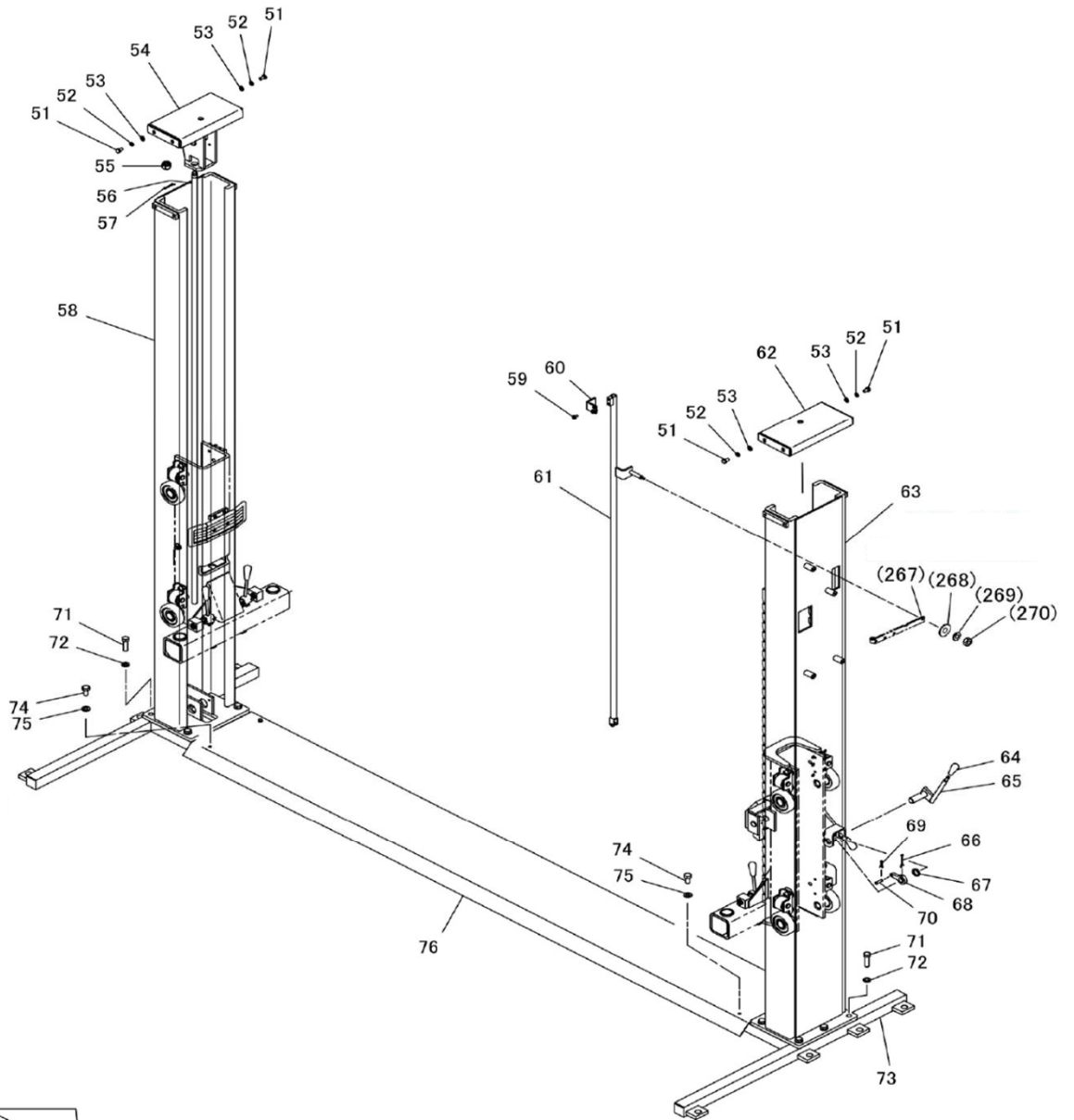

Car Entrance Direction

Post & Base

NSP3500N

Ill. No.	Parts No.	Parts Name	Standard	Change Date & Note	Qty /Unit	Price/ea.
51	90911018	Hex Bolt	HB1018SE		8	
52	90930510	Spring Washer	SW10SE		8	
53	90930710	Flat Washer	PW10SE		8	
54	00099180	S. Post Cover			1	
55	90932120	Hex Nut	CN20P1.5SE		1	
56	11315360	Safety Bar			1	
57	90974041	Cotter Pin	SP0440SE		1	
58	N/A	S. Post (Not Available because Post is structural parts)			1	N/A
59	90770815	Hex Bolt	HBS0815SE		2	
60	11315240	Rod Stopper			1	
61-1	04540120	Control Rod		Before 1703001	1	
61-2	04540121	Control Rod		After 1703002	1	
62	00099060	M. Post Cover			1	
63	N/A	M. Post (Not Available because Post is structural parts)			1	N/A
64	50561801	Grip M10	M10P1.25 (Black)		1	
65	04541260	Control Shaft			1	
66	90975050	Cotter Pin	SP0550SE		1	
67	10161831	Control Shaft Collar			1	
68	11330510	Fook Release Plate			1	
69	90973016	Cotter Pin	SP0315SE		1	
70	11317380	Crank Pin			1	
71	90901656	Hex Bolt	HB1655-10.9		10	
72	90930516	Spring Washer	SW16SE		10	
73	04546420	Base			1	
74	90910815	Hex Bolt	HB0815SE		4	
75	90930508	Spring Washer	SW08SE		4	
76	11318300	Base Cover			1	

Cylinder

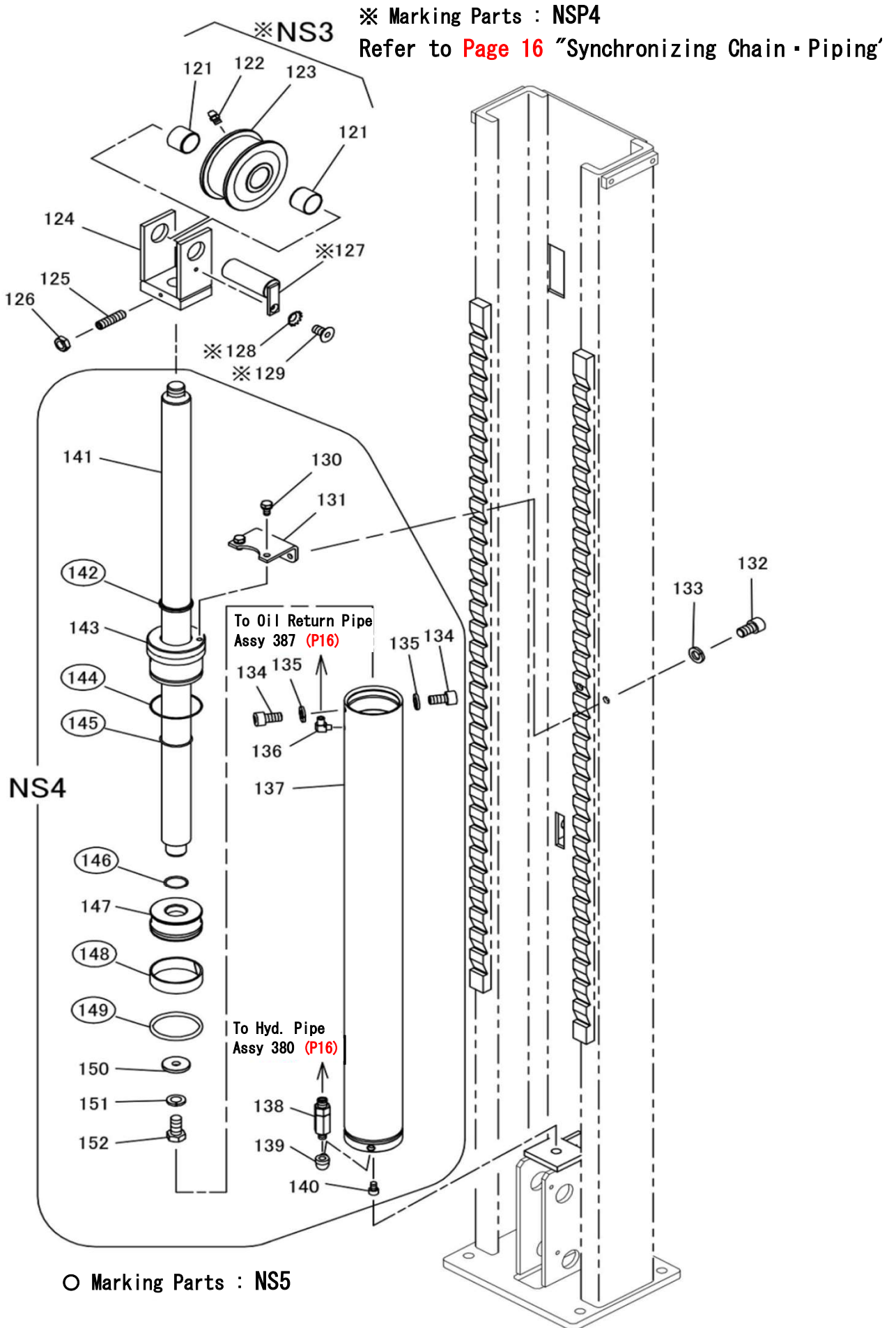

Cylinder

NSP3500N

Ill. No.	Parts No.	Parts Name	Standard	Change Date & Note	Qty /Unit	Price/ea.
NS3	00098410	Chain Wheel A Assy	(121~123)		1	
NS4	75103200	Cylinder Assy	(130·131·134~152)		1	
NS5	00043342	Seal Kit	(138·140·141·142·144·145)		1	
121	10190451	Chain Wheel Metal			2	
122	80827006	Grease Fitting	GNAM6X0. 75		1	
123	N/A	Chain Wheel A	Replace by NS3		1	N/A
124	00099540	Chain Bracket			1	
125	90960830	Hex Socket Head Screw	HSS0830		1	
126	90930308	Hex Nut	HN08 (3) SE		1	
127	04540920	Chain Wheel Shaft			1	
128	90930958	Serrated Washer	TLWF08SE		1	
129	91000815	Hex Socket Head Bolt	HSF0815		1	
130	90891020	Hex Bolt	HBS1020SE		2	
131	11250480	Cylinder Clamper			1	
132	90921220	Hex Socket Head Bolt	HSB1220		2	
133	90930512	Spring Washer	SW12SE		2	
134	90920815	Hex Socket Head Bolt	HSB0815		2	
135	90930508	Spring Washer	SW08SE		2	
136	80813906	90° Elbow	HS-E1-6X1/8		1	
137	N/A	Cylinder	Replace by NS4		1	N/A
138	80818559	Fuse Valve	FS1-02-M-30-0	(Shut Off Valve)	1	
139	80813102	Male & Female Elbow	HS-BC-1/4		1	
140	90921015	Hex Socket Head Bolt	HSB1015		1	
141	N/A	Piston Rod	Replace by NS4		1	N/A
142	80803050	Dust Seal	DH-50		1	
143	11320760	Cylinder Cover			1	
144	80800133	O Ring	G85		1	
145	80800046	O Ring	P50		1	
146	80800034	O Ring	P35		1	
147	11320780	Piston			1	
148	80804090	Wearing	84X90X25 Oiles #80		1	
149	80801080	U Packing	SKY-80 (Sakagami)		1	
150	10161161	Piston Washer			1	
151	90930412	Spring Washer	SW12		1	
152	90901225	Hex Bolt	HB1225		1	

M. Carriage Assy

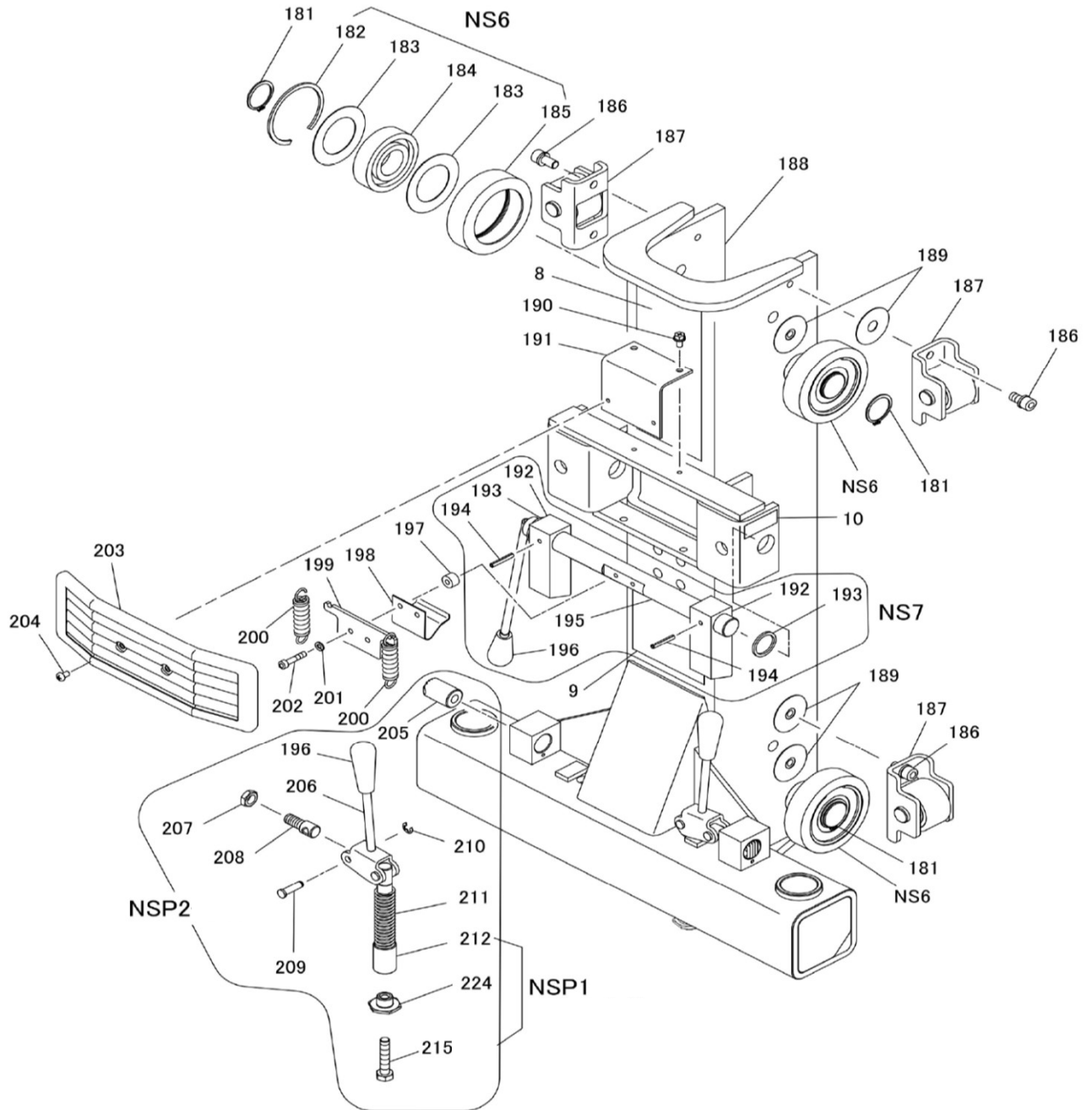

M. Carriage Assy

NSP3500N

Ill. No.	Parts No.	Parts Name	Standard	Change Date & Note	Qty /Unit	Price/ea.
NS6	75019640	Guide Roller Assy	(182~185)		4	
NS7	00098272	M. Hook Shaft Assy	(192×2·193×2·194×2·195·196)		1	
NSP1	75105000	Lock Rod Assy	(212·215·224)		2	
NSP2	75105020	Lock Link Assy	(196·205~212·215·224)		2	
8	11261820	Caution Label F	Refer to Page 26		1	
9	11261920	Caution Label	Refer to Page 26		1	
10	51311400	Function Sticker C	Refer to Page 26		1	
181	80845022	Snap Ring	RR035		4	
182	80848580	Snap Ring	BR·AR-80		4	
183	50560611	Bearing Seal			8	
184	81026307	Bearing	6307		4	
185	N/A	Guide Roller		Replace by NS6	4	N/A
186	90761020	Hex Socket Head Bolt	HSBS1020		8	
187	00099260	Side Roller			4	
188	N/A	M. Carriage (Not Available because Carriage is structural parts)			1	N/A
189	10161760	Carriage Spacer			4	
190	90790614	Hex Bolt	HBPS0614SE		2	
191	11249400	Bumper Fixing Stay			1	
192	N/A	Lowering Stop Hook		Replace by NS7	2	N/A
193	N/A	Hook Shaft Collar		Replace by NS7	2	N/A
194	90980532	Roll Pin	SRP0532		2	
195	N/A	Hook Shaft		Replace by NS7	1	N/A
196	50561801	Grip M10	M10P1. 25 (Black)		3	
197	11315710	Safety Spacer			2	
198	51311009	Safety Spring			1	
199	11315690	Safety Spring Support			1	
200	51311001	Main Safety Spring			2	
201	90930506	Spring Washer	SW06SE		2	
202	90920630	Hex Socket Head Bolt	HSB0630		2	
203	51311095	S. Door Bumper	Black		1	
204	90940610	Pan Head Screw	MSR0610SE		2	
205	11315701	Lock Piece			2	
206	04540300	Lock Link			2	
207	90930313	Hex Nut	HN12 (3) P1. 25SE		2	
208	11482400	Lock Bar			2	
209	11315621	Lock Link Pin S			4	
210	80847510	E Shape Snap Ring	E7SE		4	
211	51311040	Lock Spring			2	
212	N/A	Lock Rod	Replace by NSP1		2	N/A
215	90911051	Hex Bolt	HB1050SE		2	
224	11256960	Lock Rod Nut			2	

S. Carriage Assy

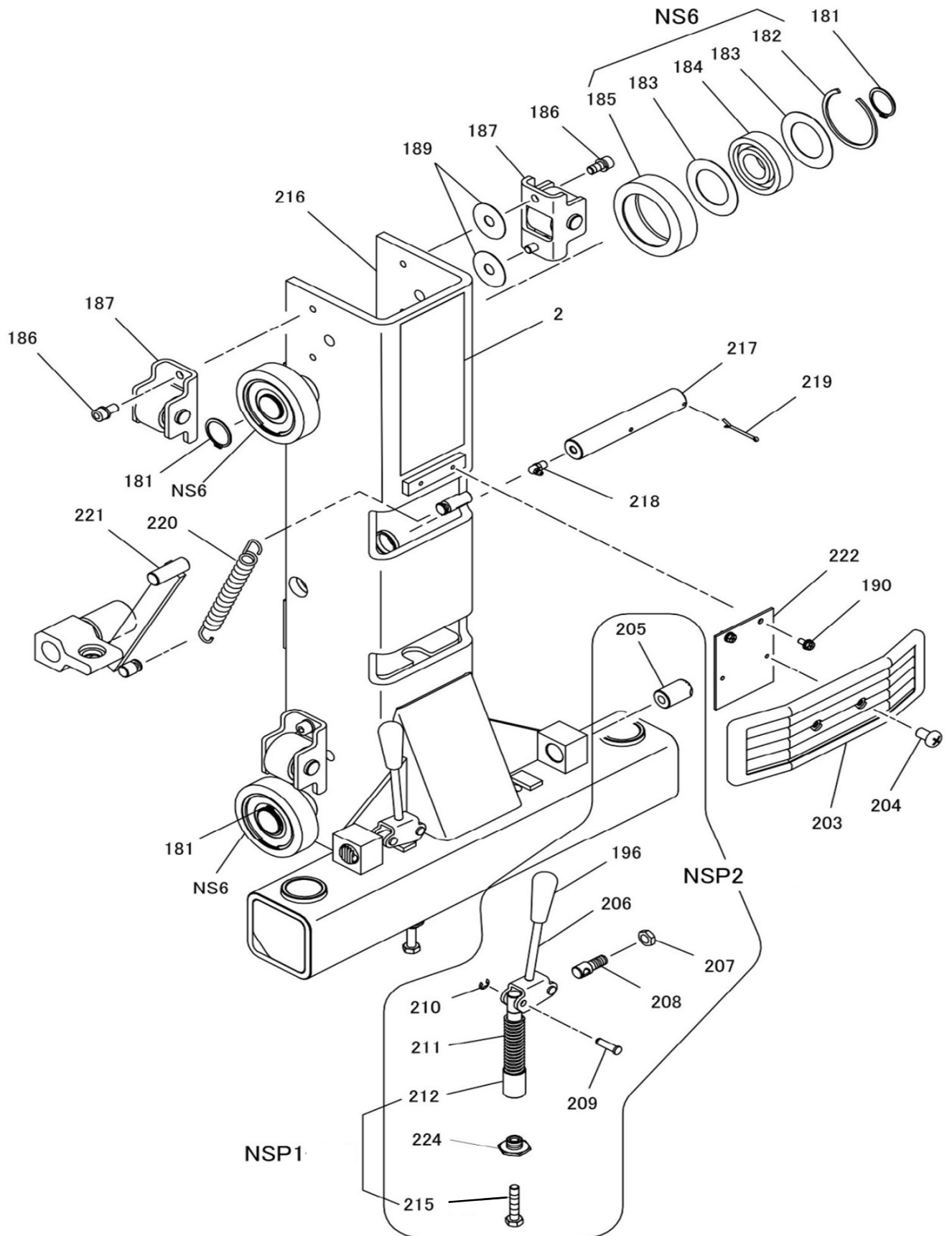

S. Carriage Assy

NSP3500N

Ill. No.	Parts No.	Parts Name	Standard	Change Date & Note	Qty /Unit	Price/ea.
NS6	75019640	Guide Roller Assy	(182~185)		4	
NSP1	75105000	Lock Rod Assy	(212·215·224)		2	
NSP2	75105020	Lock Link Assy	(196·205~212·215·224)		2	
2	11261840	Caution Label G			1	
181	80845022	Snap Ring	RR035		4	
182	80848580	Snap Ring	BR·AR-80		4	
183	50560611	Bearing Seal			8	
184	81026307	Bearing	6307		4	
185	N/A	Guide Roller		Replace by NS6	4	N/A
186	90761020	Hex Socket Head Bolt	HSBS1020		8	
187	00099260	Side Roller			4	
189	10161760	Carriage Spacer			4	
190	90790614	Hex Bolt	HBPS0614SE		2	
196	50561801	Grip M10	M10P1. 25 (Black)		2	
203	51311095	S. Door Bumper	Black		1	
204	90940610	Pan Head Screw	MSR0610SE		2	
205	11315701	Lock Piece			2	
206	04540300	Lock Link			2	
207	90930313	Hex Nut	HN12 (3) P1. 25SE		2	
208	11482400	Lock Bar			2	
209	11315621	Lock Link Pin S			4	
210	80847510	E Shape Snap Ring	E7SE		4	
211	51311040	Lock Spring			2	
212	11256940	Lock Rod	Replace by NSP1		2	N/A
215	90911051	Hex Bolt	HB1050SE		2	
216	N/A	S. Carriage (Not Available because Carriage is structural parts)			1	N/A
217	11316160	Catch Gear Shaft			1	
218	80827041	Grease Fitting	GNC1/8		1	
219	90973046	Cotter Pin	SP0345SE		1	
220	51311060	Catch Gear Spring			1	
221	00099420	Catch Gear			1	
222	11249660	Bumper Fixing Base Plate			1	
224	11256960	Lock Rod Nut			2	

Hyd. Unit and Control etc.

(After April 2016)

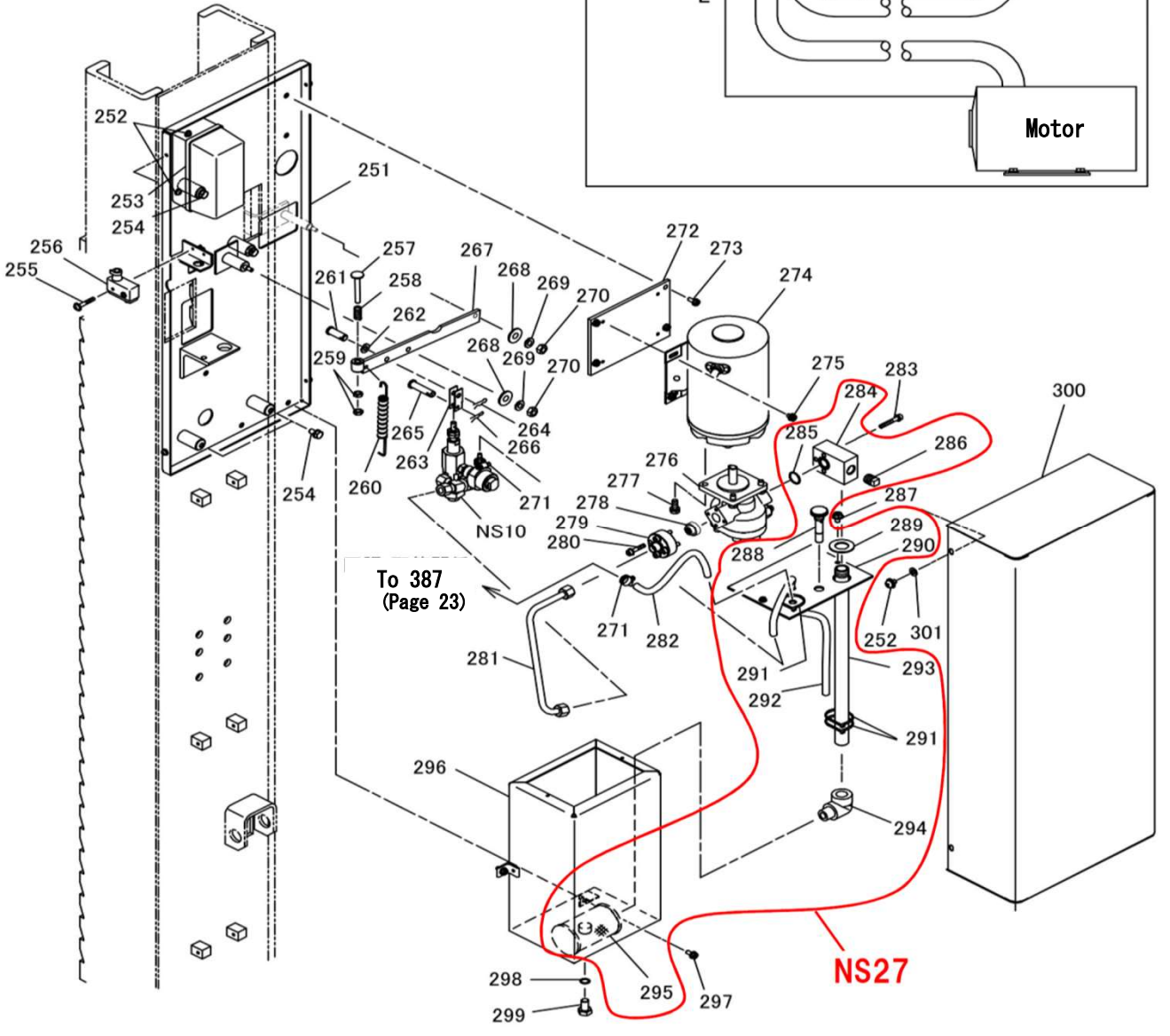
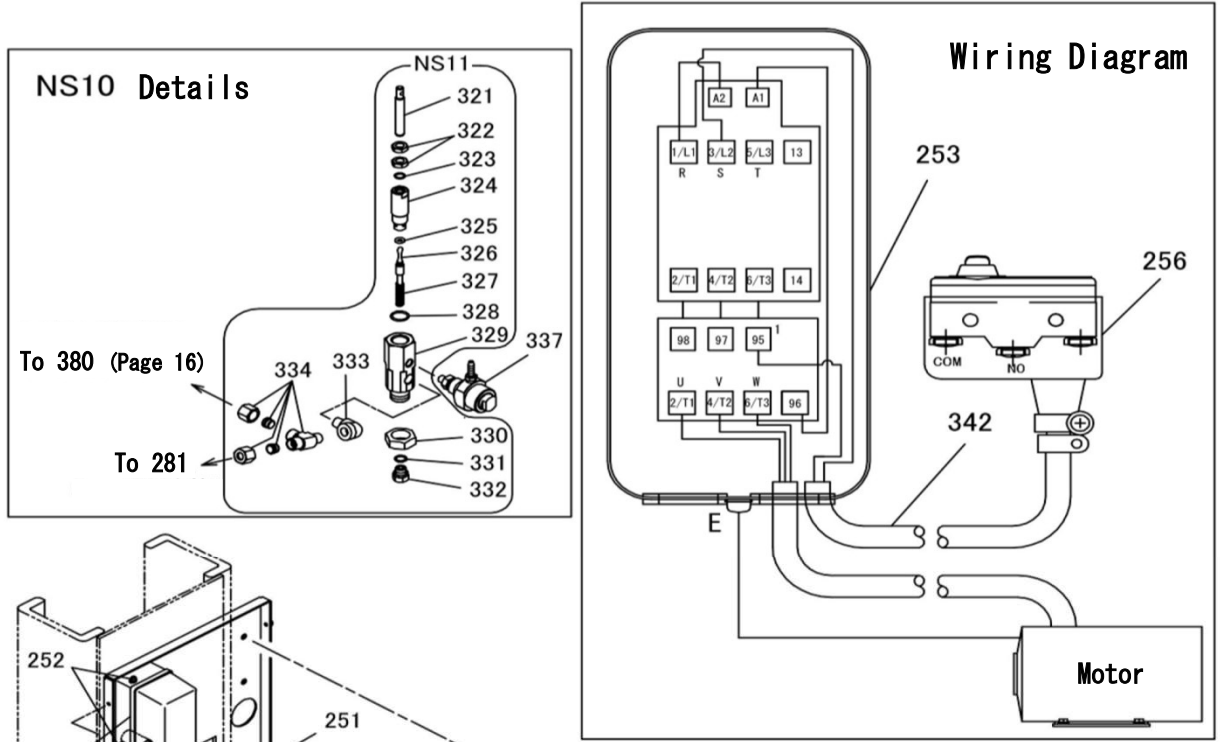

Hyd. Unit and Control etc. (After April 2016)

NSP3500N

Ill. No.	Parts No.	Parts Name	Standard	Change Date & Note	Qty /Unit	Price/ea.
NS10	04540520	Valve Complete Assy	(NS11-337)		1	
NS11	04540540	Valve Assy	(321~334)		1	
NS27	71250000	Suction Pipe Assy	(284~286·288~295)		1	
251	04540580	Control Panel			1	
252	90780508	Pan Head Screw	MSRPS0508SE		6	
253	75102500	Magnet Contactor (MS-T12-S5)	50HZ/200V, 60HZ/200 · 220V		1	
	30820720	Magnet Contactor (MS-N11-S6)	50HZ/380 · 400 · 415V, 60HZ/400 · 440V		1	
254	90890815	Hex Bolt	HBS0815SE		4	
255	90750425	Pan Head Screw	MSRP0425SE		2	
256	80820722	Limit Switch (Z-15GD-B+OM2)	50HZ/200V, 60HZ/200 · 220V - No Cable		1	
	80820756	Limit Switch (Z-15GD-B)	50HZ/380 · 400 · 415V, 60HZ/400 · 440V - No Cable		1	
257	10162722	Switch Pin			1	
258	50562721	Switch Plunger Spring			1	
259	90930308	Hex Nut	HN08 (3) SE		2	
260	50562582	Neutrizer Spring			1	
261	10161861	Conrod Fixing Pin			1	
262	90930708	Flat Washer	PW08SE		1	
263	10281761	Valve Adjuster Joint			1	
264	90654168	Snap Pin	Nominal Size 8mm		1	
265	50501681	Forked Pin			1	
266	80654165	Snap Pin	Nominal Size 5mm		1	
267-1	04540600	Switch Lever		Before 1703001	1	
267-2	04540601	Switch Lever		After 1703002	1	
268	90930793	Flat Washer	PW6. 5X19X1. 6SE		2	
269	90930506	Spring Washer	SW06SE		2	
270	90930106	Hex Nut	HN06SE		2	
271	80825054	Hose Band	SX-W1		2	
272	11258540	Motor Fixing Plate			1	
273	90770615	Hex Bolt	HBS0615SE		4	
274	80820013	Motor (TWC4712AG) 3PH 1.5KW	50HZ/200V, 60HZ/200 · 220V		1	
	80820014	Motor (TWC4712BG) 3PH 1.5KW	50HZ/380 · 400 · 415V, 60HZ/380 · 400 · 440V		1	
275	90790610	Hex Bolt	HBPS0610SE		4	
276	80818023	Gear Pump (GPE0A1-AA60L155)	50HZ/200V, 60HZ/200 · 220V		1	
	80818000	Gear Pump (GPE0A1-AA40L155)	50HZ/380 · 400 · 415V, 60HZ/380 · 400 · 440V		1	
277	90890820	Hex Bolt	HBS0820SE		4	
278	80818531	Check Valve	V1095-001		1	
279	11317580	Pump Joint			1	
280	90760630	Hex Socket Head Bolt	HSBS0630		4	
281	75103280	Unit Hyd. Pipe Assy	With Nut and Sleeve		1	
282	11317510	Overflow Tube	Spring Hose	11X6-350	1	
283	90760640	Hex Socket Head Bolt	HSBS0640		3	
284	11317500	Suction Joint			1	
285	80800018	O Ring	P20		1	
286	80810003	Plug	P3/8		1	
287	90740508	Hex Bolt	HBPO508SE		2	
288	00043644	Level Bar Assy			1	
289	11317490	Suction Pipe Cover			1	
290	11317470	Tank Cover			1	
291	80825291	Plastic Strap	CV-150		4	
292	11317520	Oil Returning Tube	Spring Hose	11X6-560	1	
293	11250000	Suction Pipe			1	
294	80810704	Male & Female Elbow	STE1/2SE		1	
295	80818951	Strainer	SS-40610-10		1	
296	00099481	Oil Tank			1	
297	90790615	Hex Bolt	HBPS0615SE		2	
298	80800250	O Ring	P12		1	
299	90911220	Hex Bolt	HB1220SE		1	
300	00043662	Control Panel Cover			1	
301	90930705	Flat Washer	PW05SE		4	
321	10162532	Valve Rod			1	
322	90930310	Hex Nut	HN10 (3) SE		2	
323	80800008	O Ring	P10		1	
324	10162521	Valve Housing			1	
325	80800220	O Ring	AN6227-1		1	

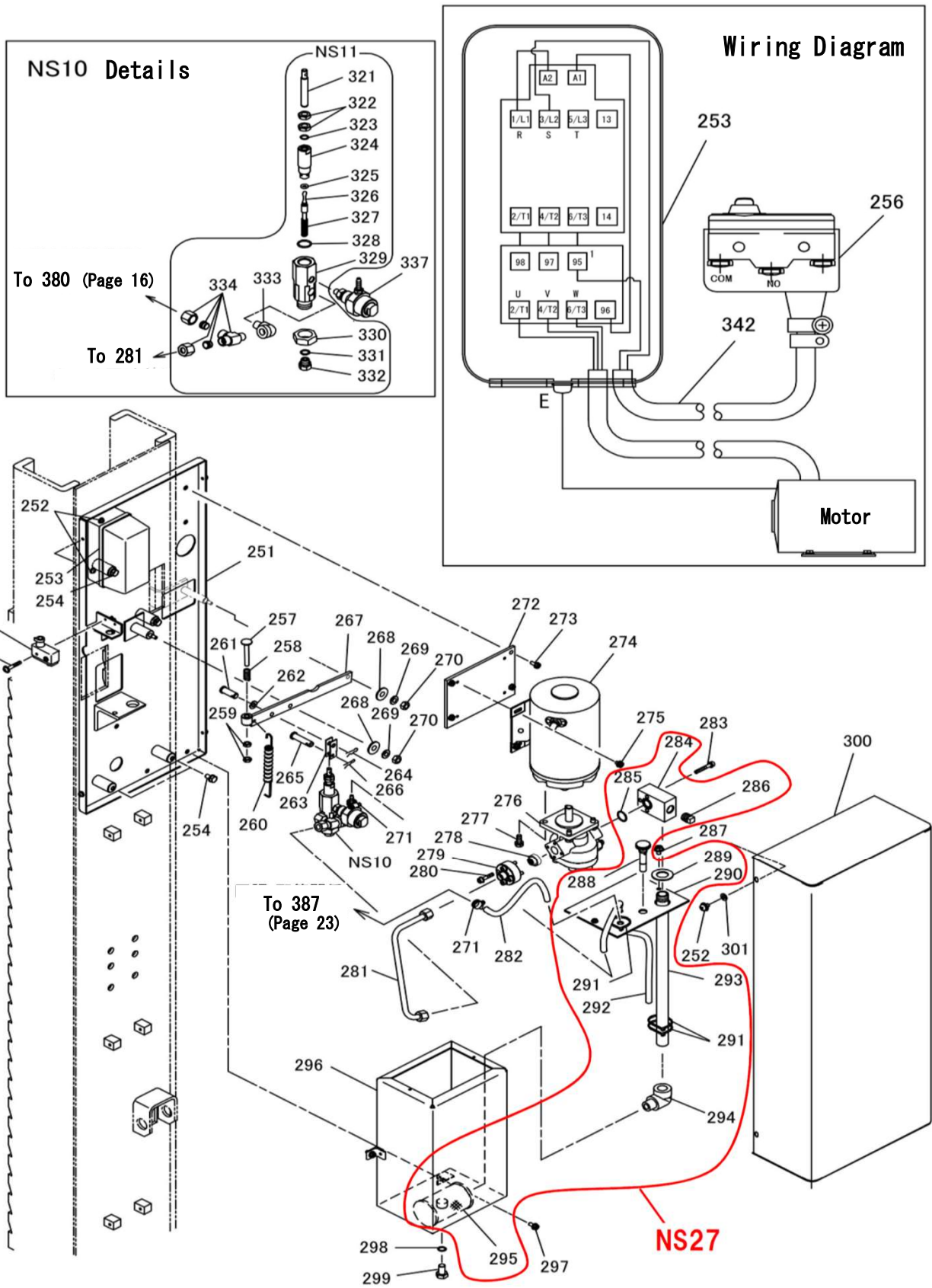

Hyd. Unit and Control etc.

NSP3500N

Ill. No.	Parts No.	Parts Name	Standard	Change Date & Note	Qty /Unit	Price/ea.
326	11250041	Valve Plunger			1	
327	50581761	Valve Spring			1	
328	80800017	O Ring	P18		1	
329	11250020	Valve Body			1	
330	90930322	Hex Nut	HN22 (3) SE		1	
331	80800411	O Ring	JASO-1011		1	
332	11250061	Back Valve Screw			1	
333	80813102	Male and Female Elbow	HS-BC-1/4		1	
334	80817520	T Nipple	KTK10-020N	(With Nut & Sleeve)	1	
	N/A	Sleeve	HS-P2-10	Replace by 334	2	N/A
	N/A	Nut	HS-C-10	Replace by 334	2	N/A
337	04540560	Flow Control Assy			1	
342	11314890	Lifting Switch Cable Set	VCTF 1.25SX2C-300		1	
	11328440	Lifting Switch Cable Set	SVCT 0.75SQX2C-300		1	

Synchronizing Chain and Piping

NSP4 : ※ Marking Parts

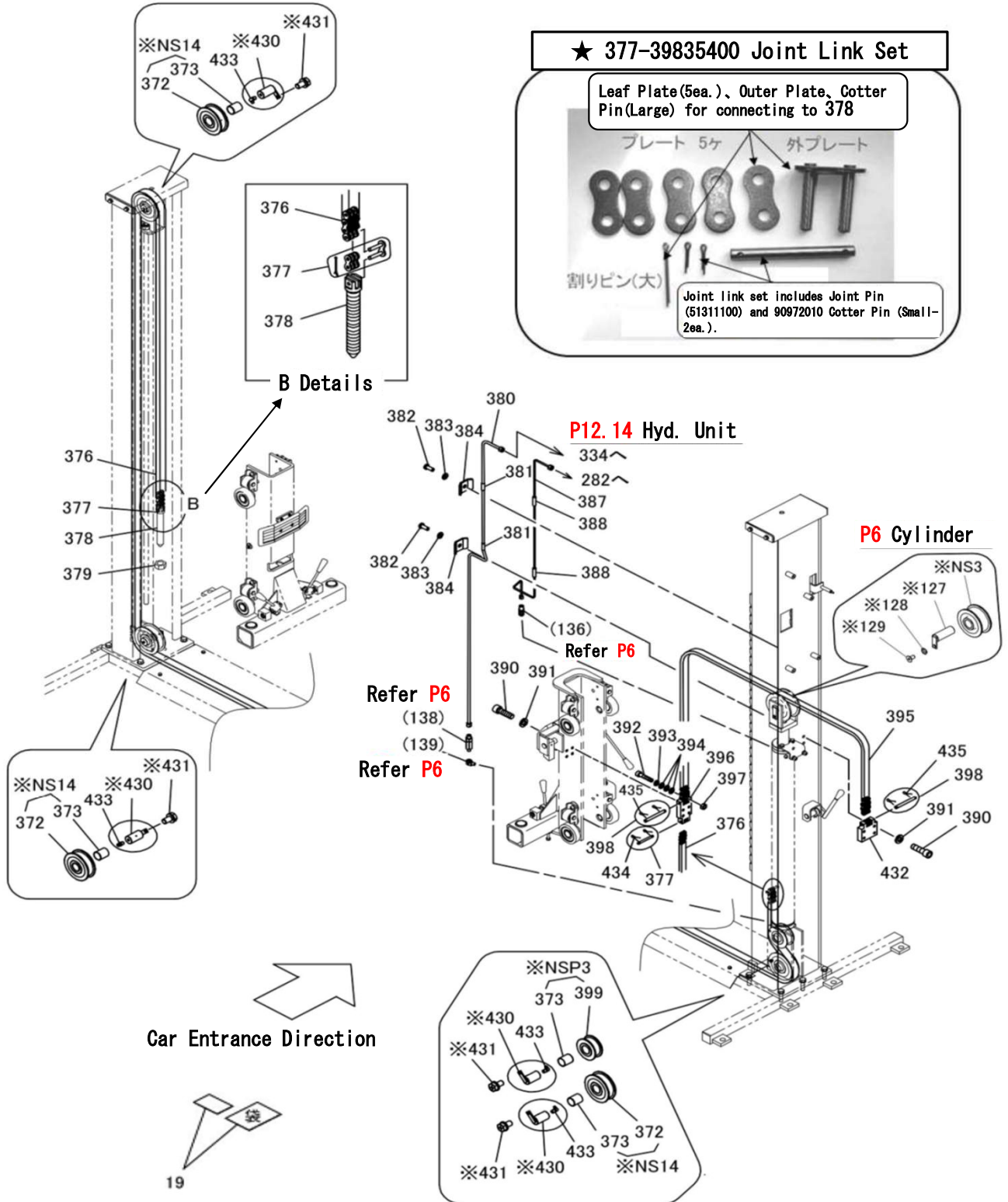

Synchronizing Chain and Piping

NSP3500N

Ill. No.	Parts No.	Parts Name	Standard	Change Date & Note	Qty /Unit	Price/ea.
NSP3	00098611	Sub Chain Wheel Assy	(373-399)		1	
NS14	00098630	Chain Wheel B Assy	(372-373)		3	
NSP4	75105040	Chain Wheel + Shaft Set	(NS3-NS14-NSP3-127~129-430-431)		1	
372	N/A	Chain Wheel B	Replace by NS14		3	N/A
373	81640445	#80 Bushing	80B-4050	Oiles	4	
376	80835535	Leaf Chain Set	AL666-465L (With 377)		1	
377	39835400	Joint Link Set	For AL666	(With 434)	1	
378	11317180	Chain Adjust Screw			1	
379	90930124	Hex Nut	HN24SE		1	
380	75103300	Hyd. Pipe Assy	With Nut, Sleeve and 381		1	
381	50627500	Fixing Pipe of Hyd. Pipe			2	
382	90940615	Pan Head Screw	MSR0615SE		2	
383	90930506	Spring Washer	SW06SE		2	
384	10161371	Fixing Pipe of Hyd. Pipe			2	
387	75103320	Oil Return Pipe Assy	With Nut, Sleeve and 388		1	
388	51311120	Fixing Pipe of R6 Hyd. Pipe	Φ7XΦ13X50		2	
390	90921240	Hex Socket Head Bolt	HSB1240		8	
391	90930512	Spring Washer	SW12SE		8	
392	90920525	Hex Socket Head Bolt	HSB0525		2	
393	90930505	Spring Washer	SW05SE		2	
394	90930705	Flat Washer	PW05SE		6	
395	80837955	Leaf Chain (With 398)	AL866-55L		1	
396	11316500	Carriage Chain Fixing Plate			1	
397	90930105	Hex Nut	HN05SE		2	
398	51311090	Chain Fitting Pin	For AL866	(With 435)	2	
399	N/A	Sub Chain Wheel	Replace by NSP3		1	N/A
430	04540720	Chain Wheel Shaft C Assy	OD-Φ40, L-72	With 433	4	
431	90770815	Hex Bolt	HBS0815SE		4	
432	11316480	Post Chain Fixing Plate			1	
433	80827041	Grease Fitting	GNC1/8		4	
434	90972011	Cotter Pin	SP0210SE	Included in 377	2	
435	90972516	Cotter Pin	SP02.515SE	Included in 398	4	
19	38000656	Chain & Cable Replacing Schedule	Label		1	

Lift Arm R·L

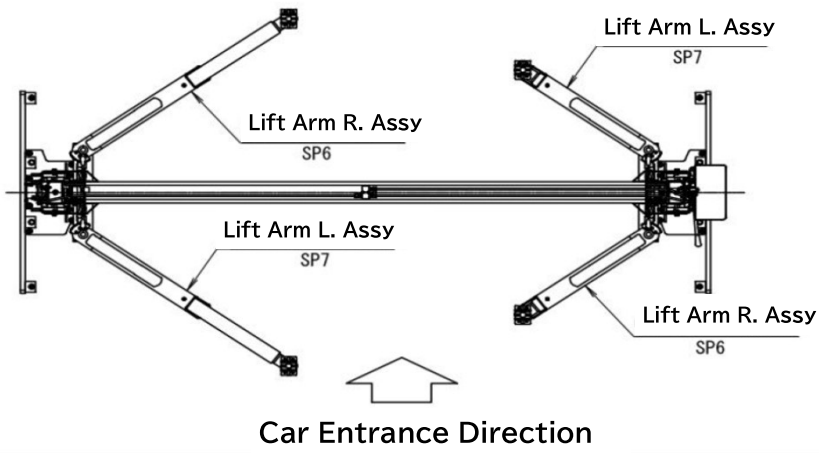

NS19 Adjustable Supporter Assy

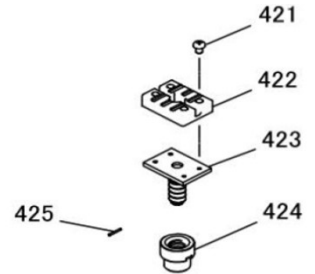

SP6 - Lift Arm R. Assy

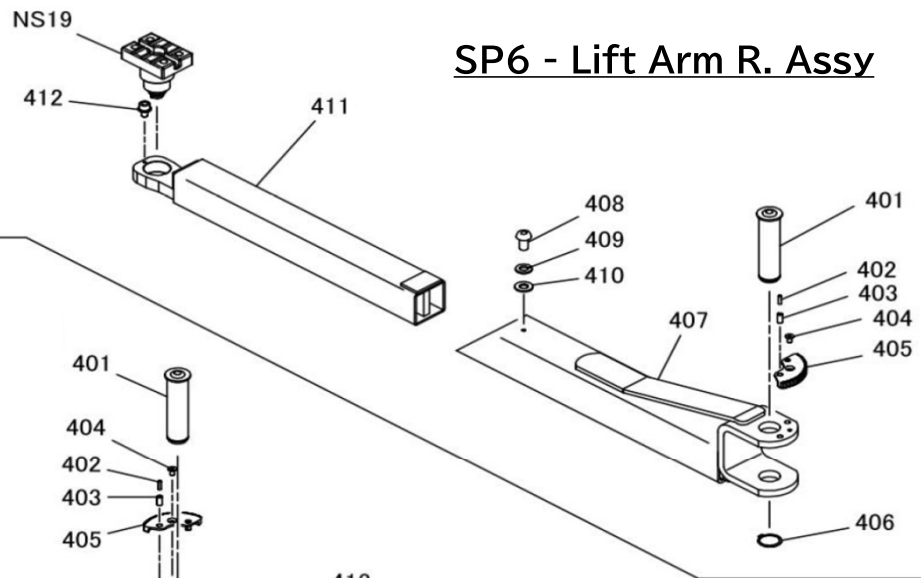

SP7 - Lift Arm L. Assy

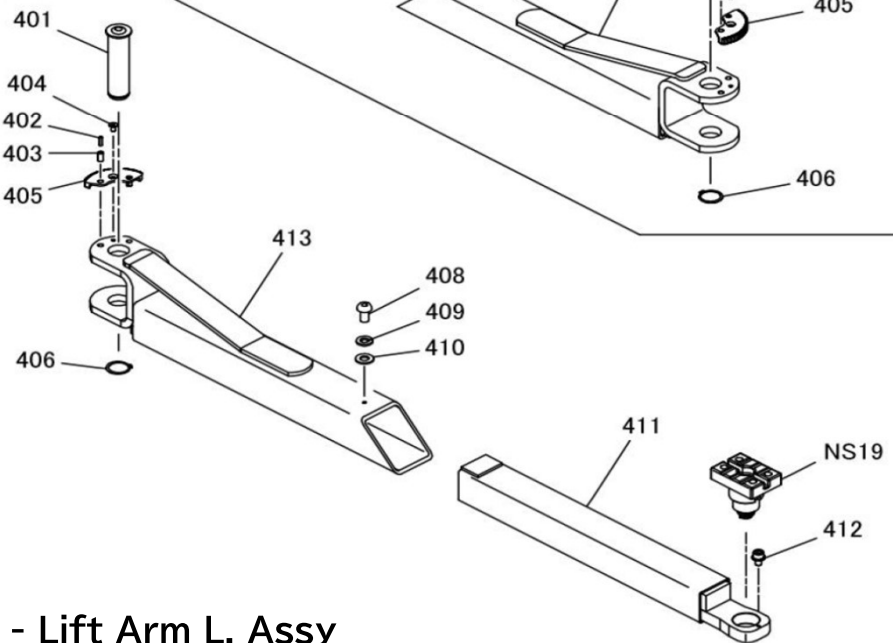

Lift Arm R·L

NSP3500N

Ill. No.	Parts No.	Parts Name	Standard	Change Date & Note	Qty /Unit	Price/ea.
SP6	04548340	Lift Arm R Assy	(401~412 · NS19)		2	
SP7	04548400	Lift Arm L Assy	(401~406 · 408~413 · NS19)		2	
NS19	00318640	Adjustable Supporter Assy	(421~425)		4	
401	00099660	Lift Arm Pin			4	
402	90980620	Roll Pin	SRP0620		8	
403	90981020	Roll Pin	SRP1020		8	
404	91000815	Socket Head Cap Bolt	HSF0815		4	
405	11316722	Lock Gear			4	
406	80845025	Snap Ring	RR040		4	
407	04548360	Lift Arm R			2	
408	91040815	Socket Head Cap Bolt	HSR0815		4	
409	90930508	Spring Washer	SW08SE		4	
410	90930708	Flat Washer	PW08SE		4	
411	04548380	L Slide Arm			4	
412	90760610	Hex Scket Head Cap Bolt	HSBS0610		4	
413	04548420	Lift Arm L			2	
421	90940810	Pan Head Screw	MSR0810SE		16	
422	11328460	Support Pad (Standard for Export - Shallow Groove)			4	
423	04540980	Adjustable Supporter			4	
424	11251260	Adjustable Nut	SRP0430		4	
425	90980430	Roll Pin	SRP0430		4	
(Option)						
	51300501	Support Pad (Deep Groove)			4	

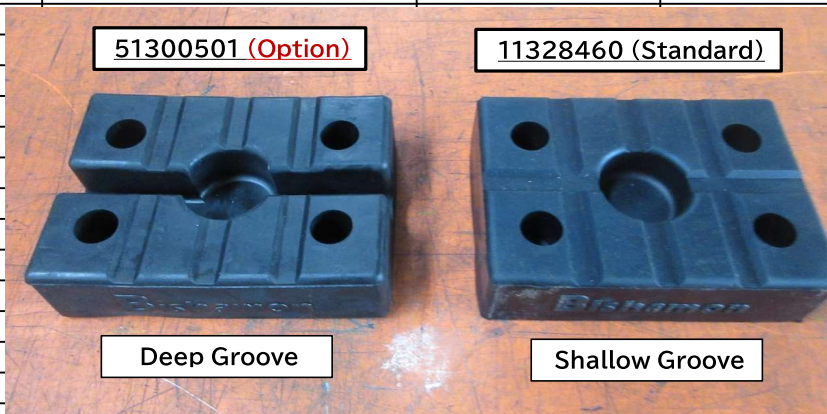

History and Applicable Adjustable Supporter Assy (Information for Reference)

(Current) After Sept. 2005

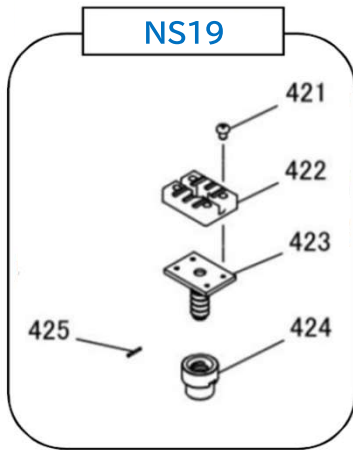

Dec. 1987 ~ Aug. 2005

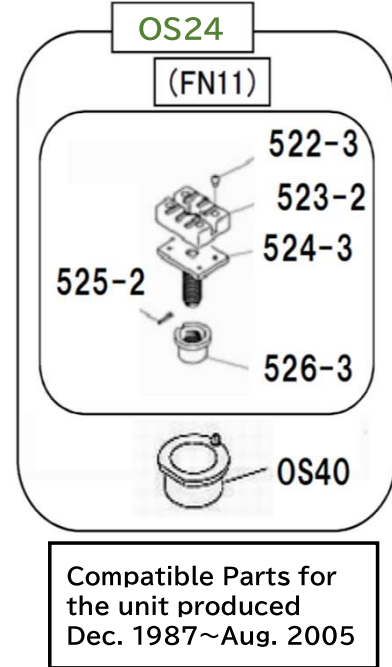

Reference Information of Very Old Adjustable Supporter

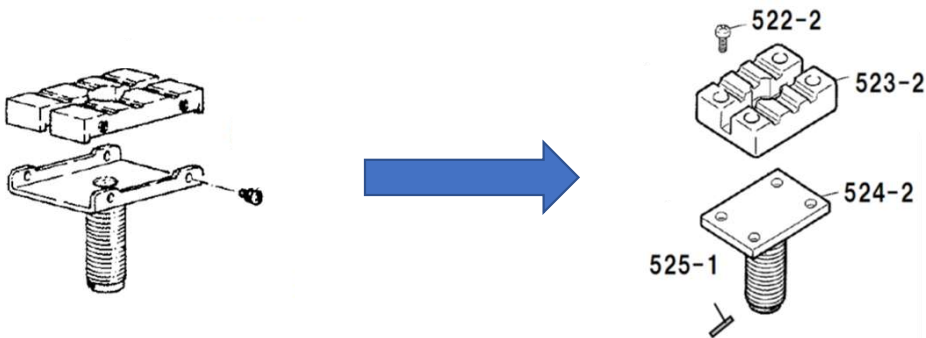

Before June 1992

※ Not Available

July 1992 ~ Aug. 2005

Can be replaced with OS24

History and Applicable Adjustable Supporter Assy

Ill. No.	Parts No.	Parts Name	Standard	Change Date & Note	Qty/Unit			Price/ea.
					OSP3000	OSP3500 OSA3500	NSP3500 NSA3500	
NS19	00318640	Adjustable Supporter Assy	(421~425)	After Sept. 2005		4		
OS24	00120410	Adjustable Supporter Assy	FN11 + OS40	Nov. 1987~Aug. 2005		4		
		Note : If Shallow groove Pad is required, Specify "With Shallow Groove Pad"						
OS40	00100090	Adjustable Nut Support		For the Arm Before Aug. 2005		4		
FN11	00140880	Adjustable Support Assy		For the Arm Before Aug. 2005		4		
421	90940810	Round Head Screw	MSR0810SE			8		
422	11328460	Support Pad	Shore 80	Export Model		2		
423	00099682	Adjustable Supporter				2		
424	11319951	Adjustable Nut				2		
425	90980430	Roll Pin	SRP0430			2		
522-2	90940812	Round Head Screw	MSR0812SE	July 1992~Aug. 2005		16		
522-3	90940810	Round Head Screw	MSR0810SE	After Sept. 2005		16		
523-2	11328460	Support Pad (New)	HS80 - Shallow Groove			4		
524-2	N/A	Adjustable Support	Replace with OS24	Before Aug. 2005		4		N/A
524-3	00099682	Adjustable Support		After Sept. 2005		4		
525-1	90980440	Roll Pin	SRP0440	Before Aug. 2005		4		
525-2	90980430	Roll Pin	SRP0430	After Sept. 2005		4		
526-3	11314980	Adjustable Nut S		After Sept. 2005		4		

Optional Frame Attachment (Truck Adaptor)

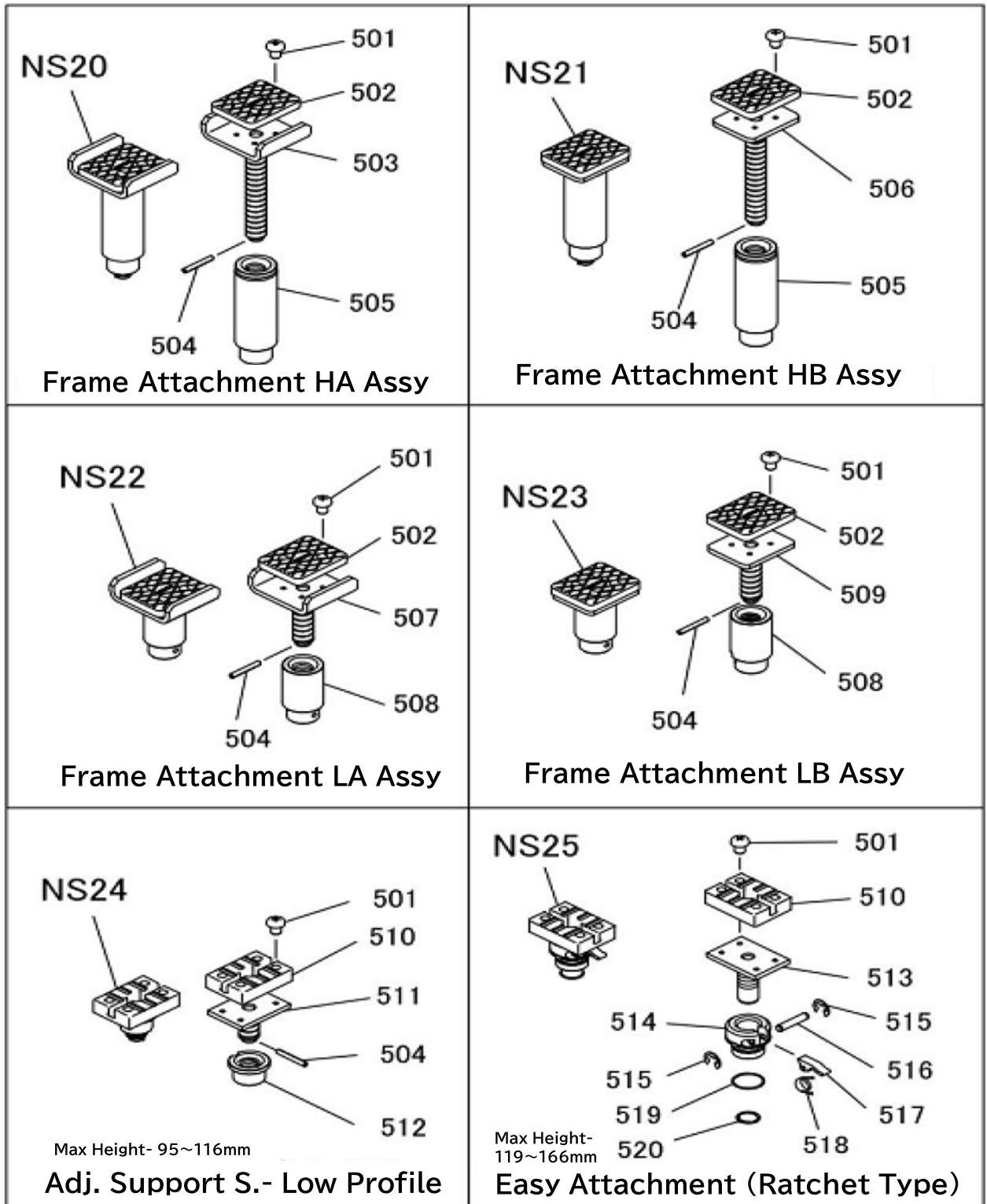

Frame Attachment Holder

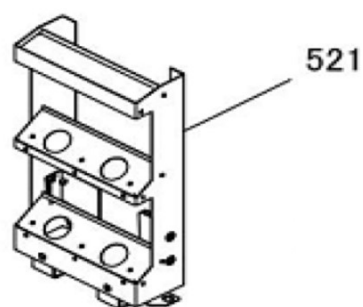

Optional Frame Attachment (Truck Adaptor)

Ill. No.	Parts No.	Parts Name	Standard	Change Date & Note	Qty/Unit			Price/ea.
					OSP3000	OSP3500 OSA3500	NSP3500 NSA3500	
NS20	04541281	Frame Attachment HA Assy	(501~505)			4		
501	90940810	Round Head Screw	MSR0810SE			16		
502	50564212	Support Pad				4		
503	04541301	Adjustable Support HA	Replace by NS20			4		
504	90980430	Roll Pin	SRP0430			4		
505	04541321	Supporter	Replace by NS20			4		
NS21	04541341	Frame Attachment HB Assy	(501・502・504~506)			4		
501	90940810	Round Head Screw	MSR0810SE			16		
502	50564212	Support Pad				4		
504	90980430	Roll Pin	SRP0430			4		
505	04541321	Supporter	Replace by NS20			4		
506	04541361	Adjustable Support HB	Replace by NS20			4		
NS22	04541380	Frame Attachment LA Assy	(501・502・504・507・508)			4		
501	90940810	Round Head Screw	MSR0810SE			16		
502	50564212	Support Pad				4		
504	90980430	Roll Pin	SRP0430			4		
507	04541400	Adjustable Support LA				4		
508	11251160	Adjustable Nut C				4		
NS23	04541420	Frame Attachment LB Assy	(501・502・504・508・509)			4		
501	90940810	Round Head Screw	MSR0810SE			16		
502	50564212	Support Pad				4		
504	90980430	Roll Pin	SRP0430			4		
508	11251160	Adjustable Nut C				4		
509	04541440	Adjustable Support LB				4		
NS24	Ask	Adjustable Support S Assy	(501・504・510~512)	Ask Bishamon		4	Ask	
501	90940810	Round Head Screw	MSR0810SE			16		
504	90980430	Roll Pin	SRP0430			4		
510	11328460	Support Pad	Shore 80	Export Model		4		
511	00100080	Adjustable Support S				4		
512	11314980	Adjustable Nut S				4		
NS25	Ask	Easy Attachment Assy	(501・510・513~520)	Ask Bishamon		4	Ask	
501	90940810	Round Head Screw	MSR0810SE			16		
510	11328460	Support Pad	Shore 80	Export Model		4		
513	N/A	Adjustable Support N	Replace with NS25			4	N/A	
514	N/A	Adjustable Nut N	Replace with NS25			4	N/A	
515	80847506	E Shape Snap Ring	E5SE			8		
516	10176340	Adjust Hook Shaft				4		
517	10176320	Adjust Hook				4		
518	10176360	Adjust Hook Spring				4		
519	80800125	O Ring	G45			4		
520	80845230	Snap Ring	ISTW30			4		
521	04541060	Attachment Holder Assy				2		

Bishamon



Sugiyasu Corporation

3-21, 4-Chome, Hongo-Cho, Takahama City,
Aichi, Japan 444-1394
Tel. 81-566-53-1126, Fax. 81-566-53-1844
<http://www.bishamon.co.jp/>